

ekinex

CONTROL YOUR LIVING SPACE

Motion sensor with 360° detection area

Code: EK-DF2-TP



Datasheet STEKDF2TP_EN



Description

The ekinex® motion sensor EK-DF2-TP is a ceiling flush mount Passive Infrared (PIR) motion detector, for the detection of movement of people in indoor spaces with a coverage area of 360°. The detection area can be extended using other sensors configured as slave devices. An integrated light sensor, combined with the motion detector, can manage light switching depending on brightness level. The device has two distinct output channels for lighting, with independent parameters; the operation can be automatic or semi automatic. The device is also capable of maintaining a constant brightness level in the room by controlling a dimmable light source. All of the above parameters can be set by the user either through ETS or by means of a dedicated IR remote during installation. The device has two additional HVAC channels, which act in a similar way as the Light Control channels but without the standby time and light level dependence. An additional alarm channel can switch the load on or off depending on the number of trigger events (movements) detected in a time frame of configurable duration.

Main features

- Semi-automatic or fully automatic operation
- Two independent Light control channels
- Two independent HVAC control channels
- One alarm channel
- An additional device can be used as slave for any of the channels
- Detection span of 360°, sectors can be masked through optical shields
- Adjustable Sensitivity, with "Walk test" to verify detection range

- Most parameters can be set from ETS or through an IR remote

Technical data:

- Rated voltage: 24 Vdc (21 - 30 Vdc) supplied by KNX bus
- Current consumption (on KNX bus): max 10 mA (operation) / 5 mA (Standby)
- Detection range: 360° circular (maskable), up to 9m diameter at 2.5m mounting height
- Light measurement range: 10..2000 Lux
- Housing, lens and frame in plastic material
- Safety standards: IEC 61000-6-1 / IEC 61000-6-3 / EN 55014 / EN 50491

Dimensions:

- Body diameter Ø 60 mm
- Rim diameter Ø 75 mm
- Mounting Hole diameter Ø 65 mm
- Total height 78 mm
- Recess depth 72 mm

Environmental conditions:

- Operating temperature: - 20 ... + 40°C
- Relative humidity: 95% not condensing
- Environmental protection: IP20

Switching, display and detection elements

The device is equipped with:

- on the rear side, a programming pushbutton
- visible through the plastic lens, a blue programming LED, a red signalling LED, a PIR sensor, a brightness sensor and an IR receiver.

Operation

The sensor reacts to the thermal radiation emitted by moving bodies; the detection area is optically divided in small sections through a composite lens. A person walking in the detection area across the sections triggers the sensor.

Brightness measurement

The measurement of the room brightness is carried out by an integrated light sensor with linear output and optical filter set on the profile of the human eye. The brightness value, measured in Lux, can be transmitted on the bus.

Lighting channel

The lighting channel has two operation modes, Automatic or Semi-automatic. The automatic mode controls both switch-on and switch-off; the semi-automatic mode only controls switch-off after a manual switch-on. The lighting source can be controlled through two different types of communication objects: On-Off switch or Absolute dimming percentage. In automatic mode, a load connected to a lighting channel will be switched on when movement is detected and (if desired) the ambient light level is below a preset brightness value. When no movement has been detected for a programmable time duration, a standby phase can be entered, during which the light can be dimmed to a lower intensity; if no further movement is detected, once stand-by time has expired, the light will be automatically switched off. Both the light level threshold and stand-by time functions can be disabled if not required.

Constant ambient brightness regulation

The internal brightness sensor can be used to maintain a constant ambient brightness if a dimmable light source is

available. The light source must be capable of being controlled through a Relative dimming communication object.

HVAC channel

The HVAC channels act in a similar way as the Light Control channels, but without the standby time and the dependence from the light level.

Positioning

The actual detection range of the sensors depends on the mounting height. For the EK-DF2-TP sensor, at a standard mounting height of 2.5 m, the motion detection range for small movements is approximately 4 meters in diameter, while the detection range for larger movements (e.g. person walking through the sensing area) is about 9 meters in diameter.

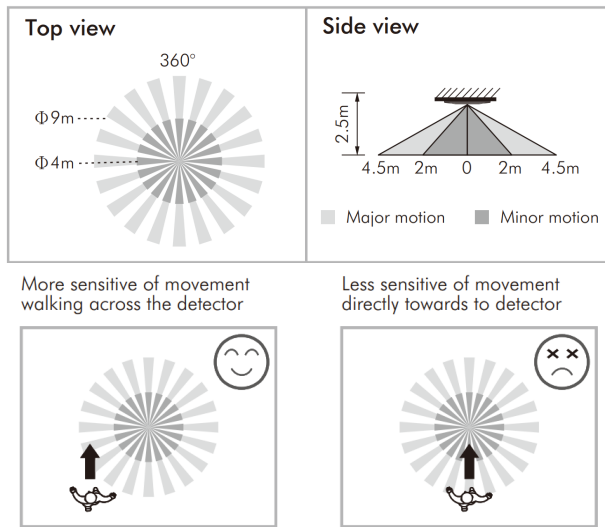

The optimal range is achieved walking through several portions of the detection area.



The recommended mounting height varies from 2 m up to 5 m.

Since the detector responds to temperature change, be aware that following conditions may cause lower sensitivity:

- In very foggy days, the sensitivity may be less due to moisture collecting on the lens.
- In very hot days, the sensitivity may be less since high ambient temperature is close to body temperature.
- In very cold days when heavy clothing is worn, especially if the facial area is covered, very little heat will be emitted from the body causing the unit to be less sensitive.

Please also verify following conditions during installation:

- Avoid pointing the detector toward objects with highly reflective surfaces, such as mirrors, glass, etc.
- Avoid mounting the detector very close to heat sources, such as heating vents, air conditioners, lights, etc.
- Avoid pointing the detector toward objects which may sway in air currents, such as curtains, tall plants, etc.



Limitation of the detection area

The detection area can be limited, in order to avoid unwanted activations, by means of the supplied optical shielding filters. Cut the supplied shield in such a way to remove the sectors corresponding to the desired detection area as in following figure:

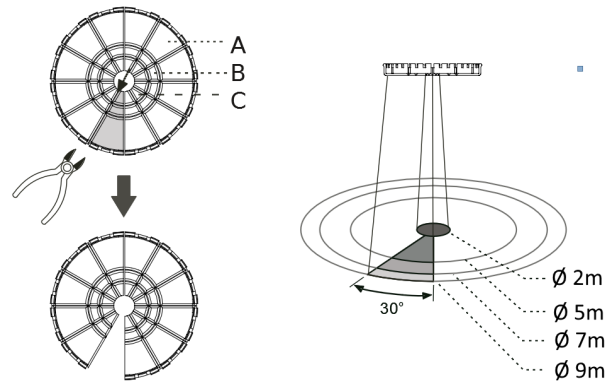

Section of shield applied	Active range (h = 2.5m)
Angular section	-30° per section
A + B + C	Ø 2 m
A + B	Ø 5 m
A	Ø 7 m
None	Ø 9 m

Apply the shield by inserting its edge between the lens and the rim:

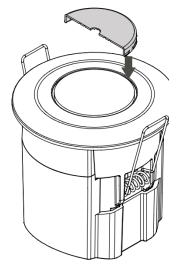

When the device is installed in place, make sure that the shield is in the correct position according to the required area masking.

Installation



Warning! The electrical connection of the device can be carried out only by qualified personnel. The incorrect installation may result in electric shock or fire. Before making the electrical connections, make sure the power supply has been turned off.

Warning! In order to supply the KNX bus lines use only KNX bus power supplies (e.g. ekinex EK-AB1- TP or EK-AG1-TP). The use of other power supplies can compromise the communication and damage the devices connected to the bus.

The device has degree of protection IP20, and is therefore suitable for use in a dry indoor environment. The device can be flush mounted through a 65 mm diameter hole on a ceiling board with 5 mm to 25 mm thickness; for solid ceilings, a plastic barrel-shaped plastic support for external mounting is available as an accessory.



Warning! Do not mount on conductive surface. Do not open the enclosure frequently. The sensor is a low voltage circuit; never connect it with the 230V line network. Do not run the KNX wiring in the same conduit used by line network wiring..



Drill a hole with $\Phi=65\text{mm}$ on the ceiling

Connect the device to the bus cable terminated by the standard terminal block on the back of the device. At this point it is recommended to carry out the commissioning of the device (see "Commissioning"), or at least the download of the physical address, using the programming button placed close to the bus connector; alternatively, programming mode can be activated later when the device is already installed by means of the IR11-KNX remote controller.

To insert the device into the hole on the ceiling board, raise and hold the spring clips; guide them into the hole and gently slide the body of the sensor until it falls into place.

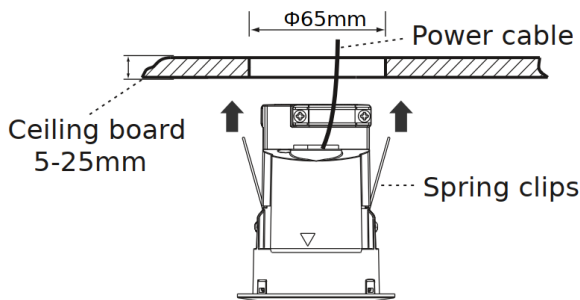

To remove the sensor, gently pry under the external rim with a screwdriver or another flat object; once you can get a firm hold with your hands on the rim, pull gently but firmly to extract the body of the sensor.



Warning! Before extracting the last part of the sensor body, please hold both spring clips with a hand. Take extreme care of preventing the clips to jump back and harm your hand holding the sensor!

See the instruction leaflet for further details on installation and commissioning).

Connection of the KNX bus line

The connection of the KNX bus line is made through the terminal block included in delivery and inserted into the slot of the housing.



IMPORTANT: It takes approximately 60 s for the sensor to warm up when power is applied before it enters normal operation mode.

Configuration and commissioning



Note. The configuration and commissioning of KNX devices require specialized skills. To acquire these skills, you should attend the workshops at KNX certified training centers.

Configuration and commissioning of the device require the use of the ETS® (Engineering Tool Software) program V4 or later releases. These activities must be carried out according to the design of the building automation system done by a qualified planner.

For the configuration of the device parameters the corresponding application program or the whole ekinex® product database must be loaded in the ETS program.

For detailed information on configuration options, refer to the application manual of the device available on the website www.ekinex.com.

Code	Application program (## = release)
EK-DF2-TP	APEKDF2TP##.knxprod

For the commissioning of the device the following activities are required:

- make the electrical connections as described above;
- turn on the bus power supply;
- switch the device operation to the programming mode by pressing the programming pushbutton; the blue programming LED (visible through the device lens) turns ON;
- download into the device the physical address and the configuration with the ETS program;

at the end of the download, the operation of the device automatically returns to normal mode. During the programming process, the programming LED is turned off.



Now the bus device is programmed and ready for use.

IMPORTANT: After a download, it takes approximately 60 s for the sensor to stabilize before it enters normal operation mode. During this settling period, the sensor may not appear to react or perform its programmed functions.

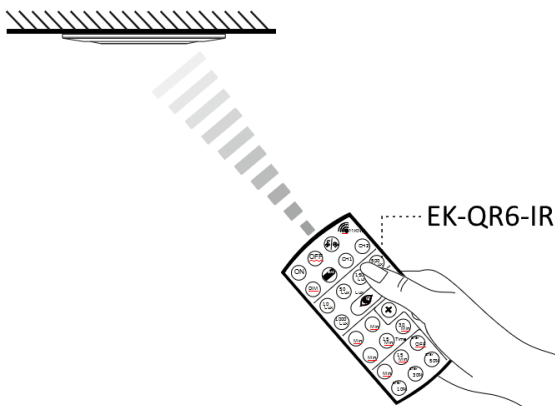
The programming pushbutton is placed on the rear side of the device, close to the KNX connector; it is therefore recommended to program at least the physical address before the device is installed on the ceiling. Once the physical address has been assigned, the device configuration can be later downloaded without pressing the programming pushbutton. If a further activation of the programming button should become necessary, the device can be switched in programming mode through the IR remote (available separately).

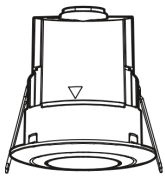
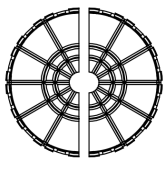

Package contents

		
EK-DF2-TP Sensor	Lens shield	Instruction sheet

Optional accessories

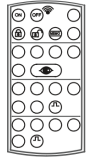
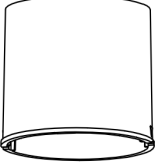
	
EK-QR6-IR remote controller	Support for external mounting

Dimensions [mm]

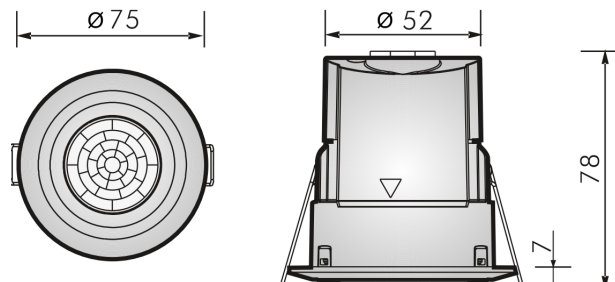

Markings

- KNX
- CE: the device complies with the Low Voltage Directive (2006/95/EC) and the Electromagnetic Compatibility Directive (2004/108/EC).

Tests carried out according to:

- EN 61000-3-2
- EN 61000-3-3
- IEC/EN 61000-6-1
- IEC/EN 61000-6-3
- EN 55014
- EN 50491

Maintenance

The device is maintenance-free. To clean it, use only a dry cloth; avoid the use of detergents, solvents or other aggressive substances, particularly on the lens.

This datasheet refers to the release A1.0 of the ekinex® device EK-DF2-TP, and is available for download at www.ekinex.com as a PDF (Portable Data Format) file.

File name	Device release	Update
STEKDF2TP_EN.pdf	A1.0	03 / 2023

Disposal



At the end of its useful life the product described in this datasheet is classified as waste from electronic equipment in accordance with the European Directive 2002/96/EC (WEEE), and cannot be disposed together with the municipal undifferentiated solid waste.



Warning! *Incorrect disposal of this product may cause serious damage to the environment and human health. Please be informed about the correct disposal procedures for waste collecting and processing provided by local authorities*

Warnings

- Installation, electrical connection, configuration and commissioning of the device can only be carried out by qualified personnel in compliance with the applicable technical standards and laws of the respective countries.
- In case of tampering, the compliance with the essential requirements of the applicable directives, for which the device has been certified, is no longer guaranteed.
- ekinex® KNX defective devices must be returned to the manufacturer at the following address: EKINEX S.p.A. Via Novara 37, I-28010 Vaprio d'Agogna (NO) Italy

Other information

- This datasheet is aimed at installers, system integrators and planners
- For further information on the product, please contact the ekinex® technical support at the e-mail address: support@ekinex.com or visit the website www.ekinex.com
- KNX® and ETS® are registered trademarks of KNX Association cvba, Brussels

© EKINEX S.p.A. The company reserves the right to make changes to this documentation without notice.