

4/8-fold KNX 20venti series pushbutton

Codes: EK-E20-TP-4TS-PN-

EK-E20-TP-4TD-PN-

EK-E20-TP-4TS-PN-



Datasheet STEKE20TP_EN

KNX 4/8-fold KNX pushbutton (4/8 independent buttons) device with integrated room temperature controller. It has to be used in KNX installations for control of homes and buildings.

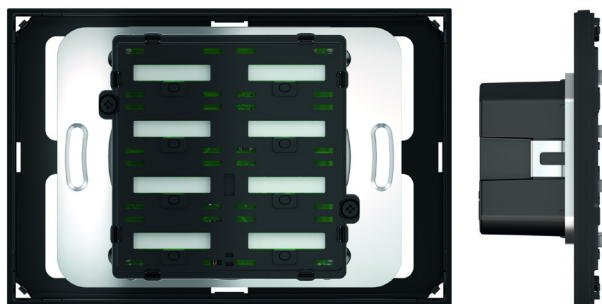
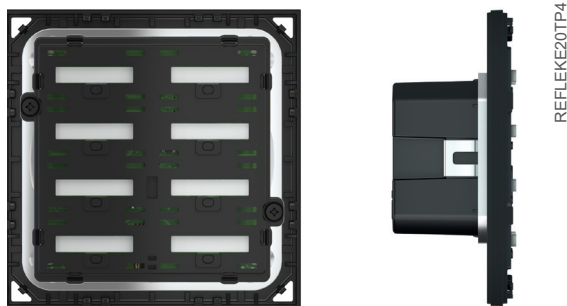

Description

The ekinex® EK-E20-TP-... 20venti series 4/8-fold pushbutton is a S-Mode KNX device for on/off switching of loads, dimming of lighting devices, controlling of motor drives or other programmable switching and control functions. The integrated temperature sensor allows to use it as a temperature controller for a room or a zone. The integrated proximity sensor enables the backlight and other features activation. It is equipped with an integrated KNX bus communication module and is designed for wall installation on flush mounting box. The device has RGB LEDs for each button configurable for example as a status signal or orientation nightlight. The pushbutton has to be completed with 4 or 8 rockers and a square or rectangular plate that have to be ordered separately. Pushing a rocker, the device sends on the bus a telegram, which is received and carried out by one or more KNX actuators. The device is powered by the KNX bus line with a SELV voltage 30 Vdc and does not require auxiliary power.



Note. The metal support, the plastic adapter, the set of rockers and the optional plate for completing the device have to be ordered separately. For more information, see also the ekinex® product catalog or browse www.ekinex.com

Versions

Code	Nr. of rockers / position	Rockers type	Proximity sensor
EK-E20-TP-4TS-P	4 / left	Text /symbols	Yes
EK-E20-TP-4TD-P	4 / right		
EK-E20-TP-8T-P.*	8	Text /symbols	Yes

(*) - Add "R" for the rectangular wall box version

Main functional characteristics

- On/off switching of single loads or groups of loads
- Dimming of lighting devices
- Control of motor drives (for roller shutters, blinds, curtains, etc.)
- Measuring of room temperature through integrated sensor
- Backlight and other features activation through integrated sensor
- Room temperature regulation
- Logic functions
- Sending of values (temperature, brightness, etc.) on the bus
- Switching to forced functioning (lock)
- Recalling and saving of scenes
- Different functions programmable for short pressure / long pressure of a rocker
- Status feedback or orientation nightlight through programmable RGB LEDs

Other characteristics

- Housing in plastic material
- Wall installation in flush mounting box
- Protection degree IP20 (according to EN 60529)
- Classification climatic 3K5 and mechanical 3M2 (according to EN 50491-2)
- Pollution degree 2 (according to IEC 60664-1)
- Weight 55 g (75 g with mounting support)
- Dimensions 80 x 80 x 20 mm (square versions), 122 x 80 x 35 mm (rectangular versions)

Technical data

- Power supply 30 Vdc from KNX bus line
- Current consumption < 17 mA
- Power from bus < 500 mW

Environmental conditions

- Operating temperature: - 5 ... + 45°C
- Storage temperature: - 25 ... + 55°C
- Transport temperature: - 25 ... + 70°C
- Relative humidity: 95% not condensing

Delivery

The fixing screws (2 pairs) and the KNX terminal block for connection of the bus line are delivered with the device. The pushbutton must be completed with a set of rockers, a metal support for wall box mounting, a plastic adapter and a plate (to be ordered separately).

Finishing set

The pushbutton has to be completed by a separate order of the following items:

- a metal support for wall mounting box;
- a plastic adapter;
- a set of rockers in plastic material that allows the use as a 4-fold or 8-fold pushbutton.
- a Deep or Surface series square or rectangular plate.

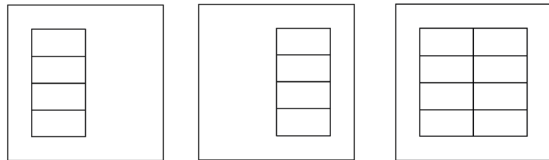

Rockers

The pushbutton has to be completed with a set of rockers in plastic material that allows the use as a 4-fold or 8-fold pushbutton. In the 4-fold configuration, the rockers are not located in central position, but either on the left or right side. Each button is equipped with RGB LEDs which can be freely programmed as status feedbacks of the loads and as orientation nightlight.

The application program allows to configure the device with ETS. The function carried out by the rocker depends on the configuration done with ETS.

Customization of rockers

The rockers are available in plastic material and several colour and finishing types, with backlit of symbols and texts with RGB LEDs, and proximity sensor.

The backlit rockers can be customized with texts. For further information see also the standard library on the ekinex® catalog or the website www.ekinex.com. On request it is also possible a customization with texts chosen by the customer.

Rocker set code *	Rocker shape	Type	Nr.	L x H [mm]
EK-T4R-20-BT-...-YYY	rectangular	Text / symbols	1	30 x 15

(*) To be completed with the extension for colour and finishing (and symbol / text where foreseen)

Finishing Plate

The device has to be completed with a ekinex® plate in plastic, metallic or Fenix NTM® material. The plate must have (at least) one 30 x 60 mm or 60 x 60 mm window and is used in combination with a plastic adapter for mounting with the Deep or Surface series.

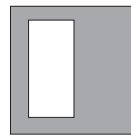

Surface or Deep square plate
with 30 x 60 mm window
Code EK-SQT-...* (Surface)
Code EK-DQT-...* (Deep)
(to be used with square versions)

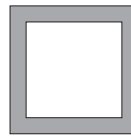

Surface or Deep square plate
with 60 x 60 mm window
Code EK-SQS-...* (Surface)
Code EK-DQS-...* (Deep)
(to be used with square versions)

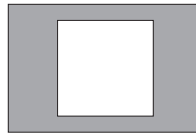

Surface or Deep rectangular plate
with 60 x 60 mm window
Code EK-SRS-...* (Surface)
Code EK-DRS-...* (Deep)
(to be used with rectangular versions)

(*) To be completed with the extension for colour and finishing

Mounting

The device has degree of protection IP20, and is therefore suitable for use in dry interior rooms. The installation of the device can be done with round, square or rectangular flush mounting box.

The installation of the device requires the following steps:

- insert the metallic support (c) on the adapter (b);
- fix adapter-support (c+b) with the screws (d) on a flush-mounting box (a) provided with suitable fixing holes;
- insert the bus terminal, previously connected to the bus cable, in its slot on the rear side (see also: "Connection of the KNX bus line");
- insert pushbutton (e) in the support-adapter (c+b). Mounting the pushbutton follow the indication TOP (arrow tip pointing up) on the front side of the device;
- tighten the pushbutton in the support-adapter (c+b) with the two screws (f) provided;
- snap the rectangular plate (g);
- snap the rockers (h) for operating the device.



Note. The screws for the metal support must be tightened with a max. torque of 1.0 Nm.

Mounting position

If the integrated sensor is used for temperature regulation, the device has to be installed preferably on an internal wall at the height of 1,5 m and at least 0,3 m far from doors. The device can not be installed close to heat sources such as radiators or household appliances or in position subjected to direct sunlight. If necessary, for the regulation can be used a weighted average value between the value measured by the integrated sensor and a value received via bus by another KNX device.

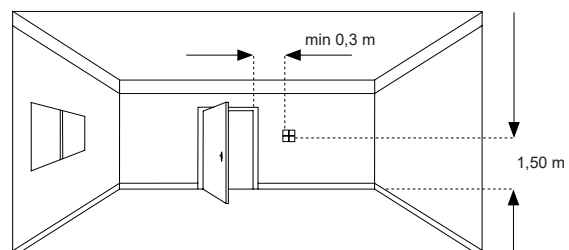

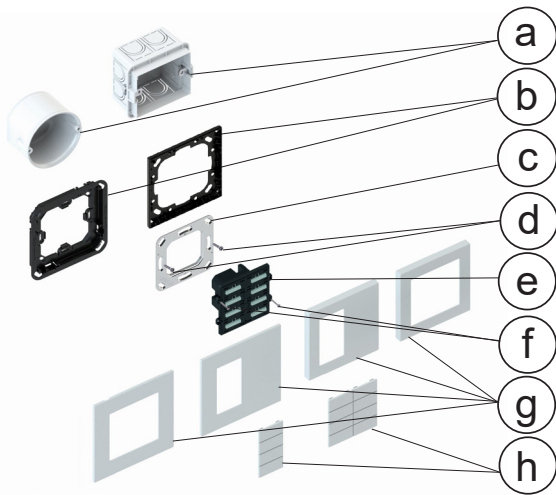

Installation for round and square flush mounting box

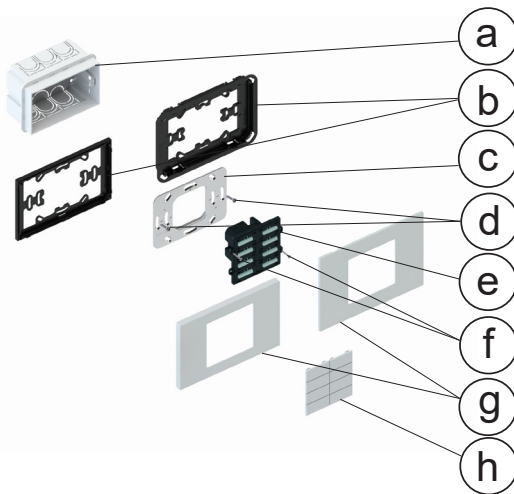

Installation for rectangular flush mounting box

- a) Wall mounting box
- b) Plastic adapter for square or rectangular plate ('NF, Surface or Deep)
- c) Metallic support for wall mounting box
- d) Screws (for metallic support)
- e) 20venti device
- f) Screws (for device)
- g) Square or rectangular Surface or Deep series plate
- h) 20venti series rockers



Note. The screws supplied in the package are suitable for standard installations. For more specific applications, where the screws have to be replaced, only flat-head screws must be used.

Use as a room temperature controller

The pushbutton can be also used as a room temperature controller for single-stage heating/cooling systems with radiators, radiant panels and electrical heaters. As the device has no user interface, it must receive the operational parameters by the bus (e.g. operating mode, seasonal conduction mode or a change of the setpoint value).

Main functional characteristics (room temperature controller)

- Temperature measuring through integrated sensor with possibility of sending the value on the bus
- 2-point (on/off) or proportional (PWM or continuous) room temperature regulation
- Seasonal conduction modes: heating and cooling with

possibility of changeover via bus or automatic depending on the configuration

- Operating modes: comfort, standby, economy and building protection with different setpoint for heating and cooling
- Automatic switching of the operating modes triggered by window opening/closing
- Weighted average of two temperature values
- Temperature control alarm
- Anti-locking function for valves (hydraulic systems)

Switching, display and connection elements

The device is equipped with mechanisms for switching, RGB LEDs for each button and a terminal block for connection of the bus line.

Switching elements

- Pushbuttons (4) for independent switching of single or group of loads (to be completed with rockers)

Display elements

- RGB LEDs (5) freely configurable e.g. for feedback status and orientation nightlight

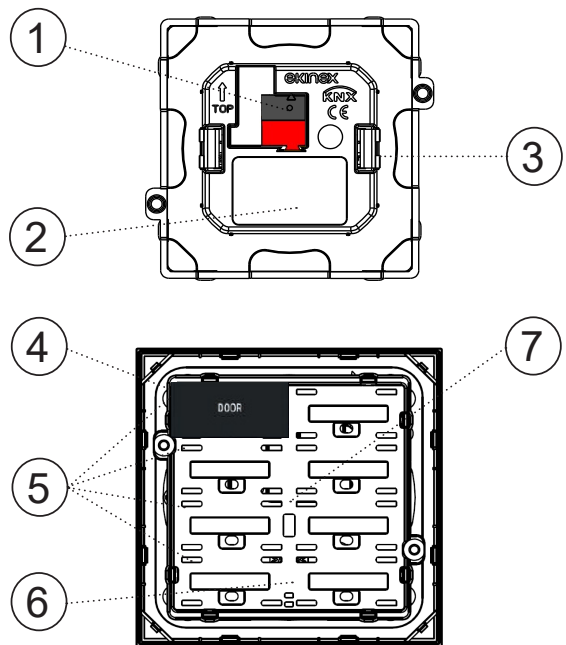

CLEKE20TP4

- 1) Connection terminal block for KNX bus line
- 2) Product label
- 3) Adapter
- 4) Rocker 30 x 15 mm
- 5) RGB LED
- 6) Position of the temperature sensor
- 7) Position of the proximity sensor

Connection of the KNX bus line

The connection of the KNX bus line is made with the terminal block (black/red) included in delivery and inserted into the slot of the housing.



Warning! The electrical connection of the device can be carried out only by qualified personnel. The incorrect installation may result in electric shock or fire. Before making the electrical connections, make sure the power supply has been turned off.

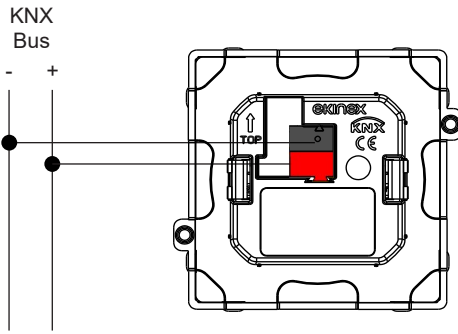

ELEKE20TP4

- switch the device operation to the programming mode by pressing simultaneously for at least 4 seconds the first and the fourth pushbuttons in the 4 buttons device, or the first and the fourth pushbuttons on the left side for the 8 buttons device (1);
- After the pushbuttons are released, all LEDs start blinking in red colour (2) and the device is in programming mode;
- download into the device the physical address and the configuration with the ETS® program.

At the end of the download the operation of the device automatically returns to normal mode; in this mode all LEDs work as programmed. Now the bus device is programmed and ready for use.

Characteristics of the KNX terminal block

- spring clamping of conductors
- 4 seats for conductors for each polarity
- terminal suitable for KNX bus cable with single-wire conductors and diameter between 0.6 and 0.8 mm
- recommended wire stripping approx. 5 mm
- color codification: red = + (positive) bus conductor, black = - (negative) bus conductor



Warning! In order to supply the KNX bus lines use only KNX bus power supplies (e.g. ekinex EK-AB1-TP or EK-AG1-TP). The use of other power supplies can compromise the communication and damage the devices connected to the bus.

Configuration and commissioning

Configuration and commissioning of the device require the use of the ETS® (Engineering Tool Software) program V4 or later releases. These activities must be carried out according to the design of the building automation system done by a qualified planner.



Note. The configuration and commissioning of KNX devices require specialized skills. To acquire these skills, you should attend the workshops at KNX certified training centers.

Configuration

For the configuration of the device parameters the corresponding application program or the whole ekinex® product database must be loaded in the ETS program. For detailed information on configuration options, refer to the application manual of the device available on the website www.ekinex.com.

Product code	Application program (## = release)	Communication objects (nr. max)	Group addresses (nr. max)
EK-E20-TP-...	APEKE20TP##.knxprod	267	254

Commissioning

For commissioning the device the following activities are required:

- make the electrical connections as described above;
- turn on the bus power supply;

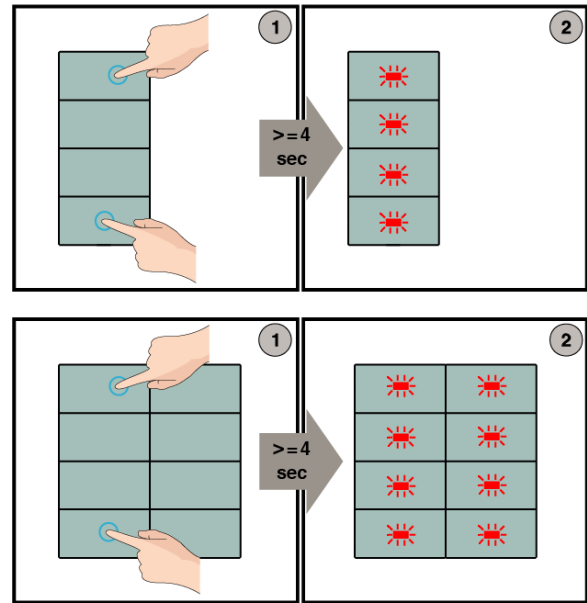

Reset of the device

To reset the device, keep the same buttons combination for entering the programming mode pressed, for at least 10 seconds. All the LEDs start blinking, then they all switch off: the reset was carried out. Now you need to address and configure again the device via ETS.



Warning! The reset restores the device back to the state of delivery from the factory. The address and the value of the parameters set during configuration will be lost.

Dimensions [mm]

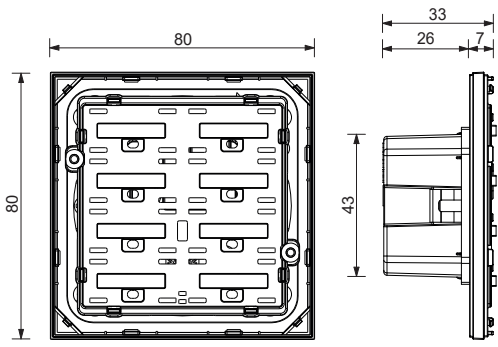

DOEKE20TP4

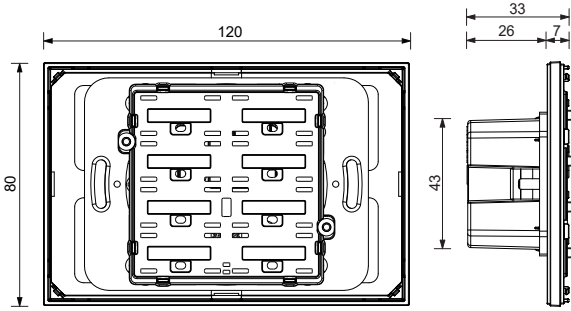

DOEKE20TP4R

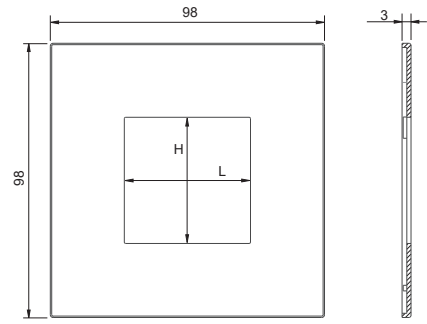
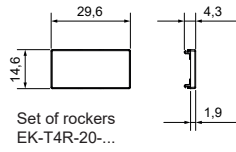

Plate EK-SQT... (4 rockers)
Plate EK-SQS... (8 rockers)
Surface series

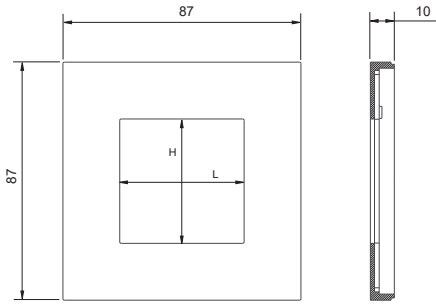
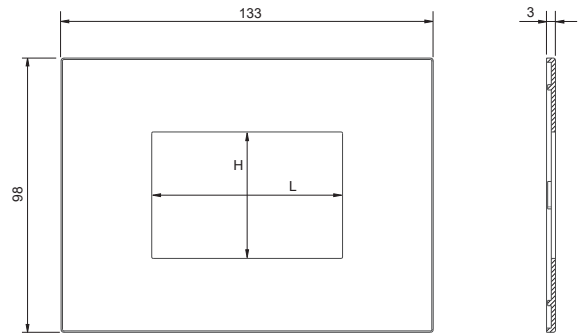
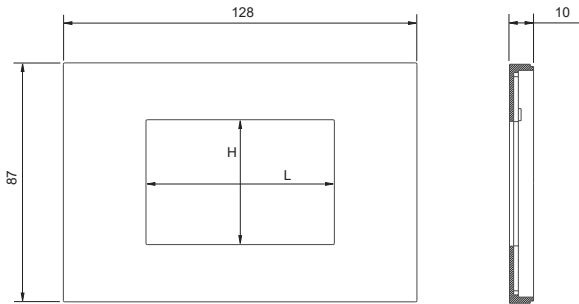

Plate EK-DQT... (4 rockers)
Plate EK-DQS... (8 rockers)
Deep series



Rectangular plate EK-SRS... Surface series



Rectangular plate EK-DRS... Deep series

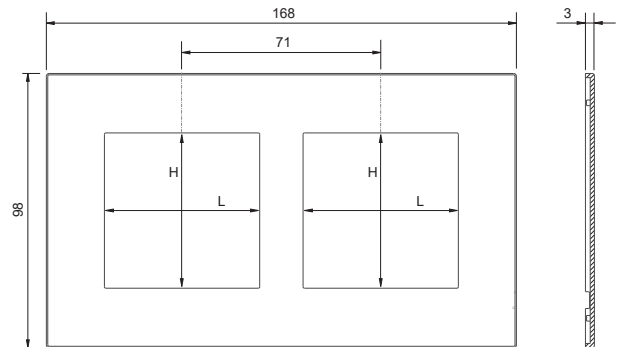

Double plate EK-S2S... Surface series

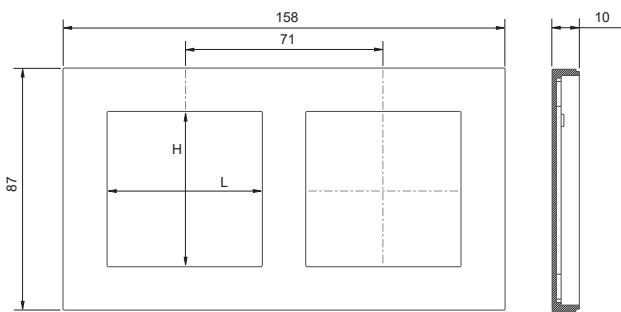

Double plate EK-D2G... Deep series

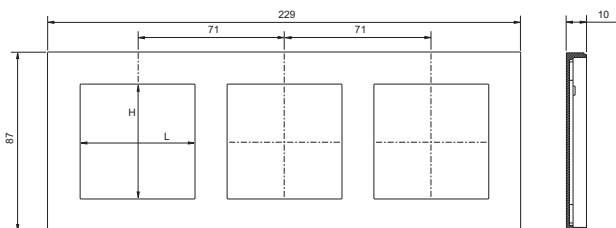

Triple plate EK-D2G... Deep series

Marks

- KNX
- CE: the device complies with the Low Voltage Directive (2014/35/EU) and the Electromagnetic Compatibility Directive (2014/30/EU). Tests carried out according to EN 63044-5-1:2019, EN 63044-5-2:2019.

Maintenance

The device is maintenance-free. To clean use a dry cloth. It must be avoided the use of solvents or other aggressive substances.

Disposal



At the end of its useful life the product described in this datasheet is classified as waste from electronic equipment in accordance with the European Directive 2012/19/EU (WEEE recast), and cannot be disposed together with the municipal undifferentiated solid waste.



Warning! Incorrect disposal of this product may cause serious damage to the environment and human health. Please be informed about the correct disposal procedures for waste collecting and processing provided by local authorities.

Documentation

This datasheet refers to the release A2.0 of the ekinex® device EK-E20-TP-..., and is available for download at www.ekinex.com as a PDF (Portable Data Format) file.

File name	Device release	Updating
STEKE20TP4_EN.pdf	A2.0	05 / 2022

Warnings

- Installation, electrical connection, configuration and commissioning of the device can only be carried out by qualified personnel in compliance with the applicable technical standards and laws of the respective countries
- Opening the housing of the device causes the immediate end of the warranty period
- In case of tampering, the compliance with the essential requirements of the applicable directives, for which the device has been certified, is no longer guaranteed
- ekinex® KNX defective devices must be returned to the manufacturer at the following address: EKINEX S.p.A. Via Novara 37, I-28010 Vaprio d'Agogna (NO) Italy

Other information

- This datasheet is aimed at installers, system integrators and planners
- For further information on the product, please contact the ekinex® technical support at the e-mail address: support@ekinex.com or visit the website www.ekinex.com
- Each ekinex® device has a unique serial number on the label. The serial number can be used by installers or system integrators for documentation purposes and has to be added in each communication addressed to the EKINEX technical support in case of malfunctioning of the device
- KNX® and ETS® are registered trademarks of KNX Association cvba, Brussels

© EKINEX S.p.A. The company reserves the right to make changes to this documentation without notice.

Annex 1. Installation

The 4/8-fold KNX 20venti series pushbutton comes with an integrated KNX communication module. It is suitable for mounting into a flush-mounting box, either round (q) or square (r), provided with fixing holes 60 mm apart.

It can also be installed into a rectangular wall mounting box (s) 3-seater according to the Italian installation standard provided with fixing holes 83,5 mm apart. Each pushbutton is delivered with screws for mounting and a KNX terminal block. The metal support (k, l) and the plastic adapter (m, n, o, p) have to be ordered separately.

The pushbutton must be finished off with a set of rockers and a plate with at least a 30 x 60 mm window. The rockers (i, j) are available in a rectangular shape, in plastic material.

Each device has integrated RGB LEDs with lightguides for feedback status and 2 sensors (temperature and proximity).

The square (c, d, e, f) and rectangular (g, h) plates are available in 'NF, Deep or Surface stylish alternatives and made of plastic, aluminium or Fenix NTM® materials, along with several colours and finishings.

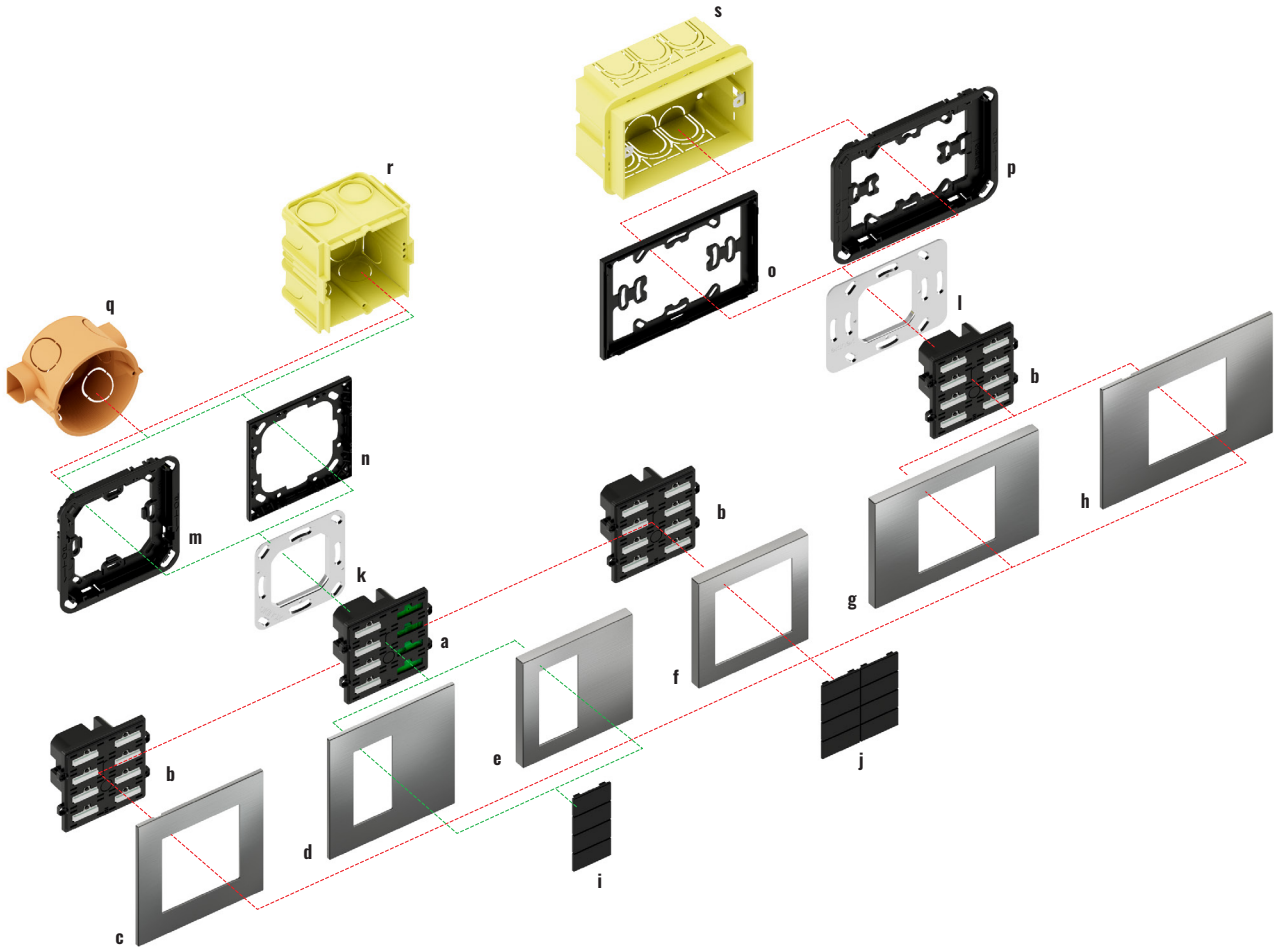

Legend

Description	Code
a) Pushbutton 20venti series 4 backlit rockers w. prox. sensor	EK-E20-TP-4T...
b) Pushbutton 20venti series 8 backlit rockers w. prox. sensor	EK-E20-TP-8T...
c) Square plate Surface series (60 x 60 mm window)	EK-SQS-...
d) Square plate Surface series (30 x 60 mm window)	EK-SQT-...
e) Square plate Deep series (30 x 60 mm window)	EK-DQT-...
f) Square plate Deep series (60 x 60 mm window)	EK-DQS-...
g) Rectangular plate Deep series (60 x 60 mm window)	EK-DRS-...
h) Rectangular plate Surface series (60 x 60 mm window)	EK-SRS-...
i) Rectangular rockers (4)	EK-T4R-20-...
j) Rectangular rockers (8)	EK-T4R-20-...

Description	Code
k) Metal mounting support	EK-SMQ-71
l) Metal mounting support with adapter	EK-SMR-71
m) Adapter for square Surface plate	EK-TAS-Q-...
n) Adapter for square plate 'NF and Deep series	EK-TAQ-...-NF
o) Adapter for rectangular plate 'NF and Deep series	EK-TAR-...-NF
p) Adapter for Surface rectangular plate	EK-TAS-R-...
q) Round flush-mounting box	not delivered by ekinex®
r) Square flush-mounting box	not delivered by ekinex®
s) Rectangular flush-mounting box (3 modules)	not delivered by ekinex®