

## Product and Applications Description

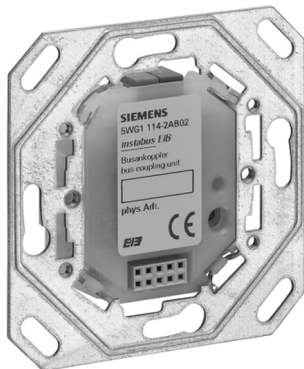

The bus coupling unit (BCU) UP 114/02 enables application units (AUs) to be connected to the bus line via the physical external interface (PEI). It contains a BCU 2.0 and is required for extensive application programs.

The telegrams received via the bus line are processed by the bus coupling unit (BCU) and passed on to the application unit. In the opposite direction, signals coming from the AU are converted into telegrams and transmitted.

The bus coupling unit UP 114/02 is directly connected to the bus line. It constantly monitors the bus and thus continuously is aware of whether the line is clear for sending or busy with other telegrams. Upon appropriate events the BCU will send immediately provided the bus is not busy. Otherwise the sending request will be postponed until the line is disengaged.

The BCU is attached to box mounts, Ø 60 mm, with screw mounts (claw-less). The connection to the bus line is established via screwless plug-in terminals (bus connection block 193).

The application units (e.g. push button UP 231) are slid onto the BCU with guide and mounting clamps.

When connected to the bus with reversed polarity the bus coupling unit UP 114/02 is switched off (reverse voltage protection). If the voltage of the bus line decreases to below the minimum voltage of approx. DC 21 V, the required data is saved by writing it to the BCU's EEPROM. The application unit is set to corresponding mode as specified in the parameter list for this case (depending on application program).

## Application Programs

With the ETS (*EIB Tool Software*) the application program is selected, its parameters and addresses are assigned appropriately and downloaded to the bus coupling unit.

The description of the application programs is included in the appropriate application unit to which it belongs.

## Example of Operation

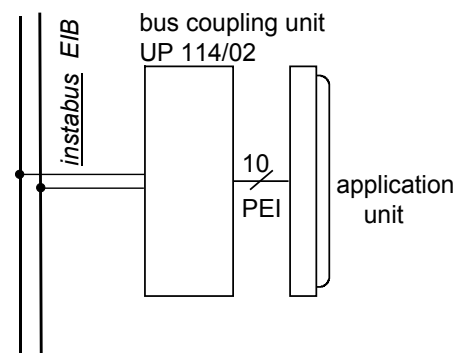

## Installation Instructions

- The device may be used for permanent interior installations in dry locations within box mounts.



### WARNING

- The device must be mounted and commissioned by an authorised electrician.
- The device must not be mounted in box mounts together with 230 V devices and/or 230 V cables.
- The device may be mounted to switch and socket combination box mounts if VDE-certified devices are used exclusively.
- The prevailing safety rules must be heeded.
- The device must not be opened. A device suspected faulty should be returned to the local Siemens office.

### Technical Specifications

#### Power supply (via bus)

- rated voltage: DC 24 V
- operating voltage: min. DC 21 V , max. DC 30 V

#### Power input

max. 220 mW

#### Physical external interface - application unit

- supply voltage:  
DC 5 V and/or DC 24 V
- power intake: max. 50 mW

#### Operator elements

1 learning button:  
for switching between normal operating mode and addressing mode

#### Display elements

1 red LED:  
for monitoring bus voltage and displaying mode, selected with the learning button

#### Connections

- 10-pin socket (PEI): for connection an application unit
- bus line, screwless bus connection block  
Ø 0,6...0,8 mm single core

#### Physical specifications

- housing: plastic
- dimensions:
  - spacing dimensions: 71 x 71 mm
  - mounting depth: 16 mm
- weight: approx. 45 g (incl. mounting hanger)
- fire load: approx. 520 kJ ± 10 %
- installation: mounting in box mounts  
Ø 60 mm, 40 mm deep

#### Electrical safety

- fouling class (according to IEC 664-1): 2
- protection (according to EN 60529): IP 20
- protection class (according to IEC 1140): III
- overvoltage class (according to IEC 664-1): III
- bus: safety extra low voltage SELV DC 24 V
- device complies with  
EN 50090-2-2 and IEC 664-1:1992

#### Reliability

rate of failure: 310 fit at 40 °C

#### Electromagnetic compatibility

complies with  
EN 50081-1, EN 50082-2 and EN 50090-2-2

### Environmental specifications

- climatic conditions: EN 50090-2-2
- ambient temperature operating: - 5 ... + 45 °C
- storage temperature: - 25 ... + 70 °C
- relative humidity (non-condensing): 5 % to 93 %

### Certification

EIB certificate

### CE norm

complies with the EMC regulations (residential and functional buildings), and low voltage regulations

### Location and Function of the Display and Operator Elements

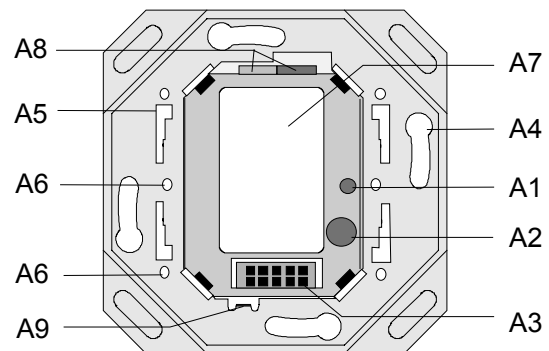

Figure 1: Location of the display and operator elements

- A1 LED for indicating normal operating mode (LED off) and addressing mode (LED on); upon receiving the physical address the device automatically returns to normal operating mode
- A2 Learning button for switching between normal operating mode and addressing mode
- A3 Physical external interface (PEI) for connecting an application unit
- A4 Slots for attaching the bus coupling unit to box mounts
- A5 Slots for mounting application unit with guide and mounting clamps
- A6 Thread for mounting screws (for additional support, e.g. for securing the application unit against theft)
- A7 Type plate
- A8 Bus connection block for single core conductors: Ø 0,6 ... 0,8 mm
- A9 earthing plate

**Bus Coupling Unit UP 114/02****5WG1 114-2AB02****Mounting and Wiring**General description

The connection to the bus line is established via bus connection block 193 (screwless plug-in terminals for single core conductors). The application unit, e.g. a push button UP 210 is slipped onto the bus coupling unit via guide and mounting clamps and, depending on the device type, fastened with screws.

**Note**

The bus coupling unit UP 114/02 must be mounted with the physical external interface (PEI) situated at the bottom (see Figure 2). Thus, the application unit will be oriented properly when slid onto the PEI. For achieving a permanent stable contact at the PEI, the exclusive use of bus devices provided with mounting screws is recommended.

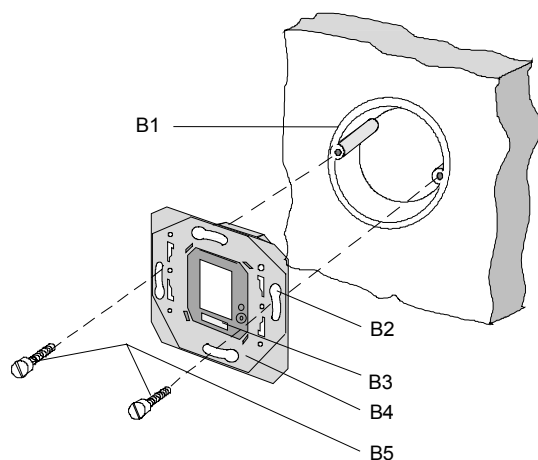

Figure 2: Mounting the bus coupling unit UP 114/02

- B1 box mount (60 mm Ø, according to DIN 49073)
- B2 mounting slots
- B3 physical external interface (PEI)
- B4 bus coupling unit UP 114/02
- B5 mounting screws

Slipping off/on bus connection blocks (figure 3)

The bus connection block (C2) is situated on the back of the bus coupling unit (C1). It consists of two components (C2.1 and C2.2) with four terminal contacts each. Take care not to damage the two test sockets (C2.3) by accidentally connecting them to the bus cable or with the screw driver (e.g. when attempting to unplug the bus connection block).

Slipping off bus connection blocks (figure 3)

- Carefully put the screw driver to the wire inserting slit of the bus connection block's grey component (C2.2) and
- pull the bus connection block (C2) from the bus coupling unit UP 114/02 (C1).

**Note**

Don't try to remove the bus connection block from the bottom side. There is a risk of shorting-out the device!

Slipping on bus connection blocks (figure 3)

- Slip the bus connection block (C2) onto the guide slot of the bus coupling unit UP 114/02 (C1) and
- press the bus connection block (C2) down to the stop.

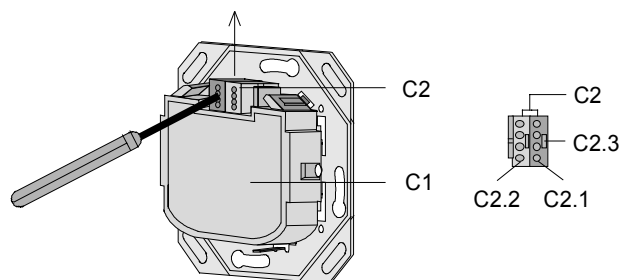

Figure 3: Slipping off/on bus connection blocks

Connecting bus cables (figure 4)

- The bus connection block (D1) can be used with single core conductors Ø 0,6 ... 0,8 mm.
- Remove approx. 5 mm of insulation from the conductor (D2) and plug it into the bus connection block (D1) (red = +, grey = -).

Disconnecting bus cables (figure 4)

- Unplug the bus connection block (D1) and remove the bus cable conductor (D2) while simultaneously wiggling it.

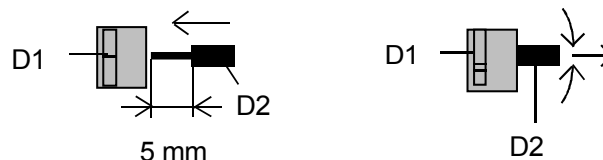

Figure 4: Connecting/disconnecting a bus cable

**Dimension Diagram**

Dimensions in mm

