

DELTA i-system	Coupler wave / <u>instabus</u>	UP 140	5WG3 140-2HB_1
DELTA profil	Coupler wave / <u>instabus</u>	UP 140	5WG3 140-2AB_1
DELTA style	Coupler wave / <u>instabus</u>	UP 140	5WG3 140-2GB_1

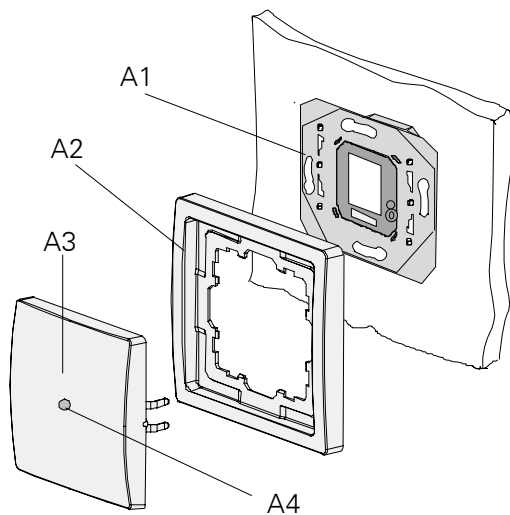

Product	DELTA i-system	DELTA profil	DELTA style
Coupler wave / <u>instabus</u>	5WG3 140-2HB11 titanium white	5WG3 140-2AB01 pearl grey	5WG3 140-2GB11 titanium white
	5WG3 140-2HB21 carbon metallic	5WG3 140-2AB11 titanium white	5WG3 140-2GB21 basalt black
	5WG3 140-2HB31 aluminum metallic	5WG3 140-2AB21 anthracite	5WG3 140-2GB41 platinum metallic
		5WG3 140-2AB71 silver	
Frame	must be separately ordered from the DELTA product range		
	---	cut-out frames	---
Bus coupling unit	UP 114		



- A 1 Bus coupling unit UP 114
- A 2 Frame
- A 3 Coupler wave / instabus UP 140 \*)
- A 4 LED \*)

\*) included with supply

Diagram A: Mounting the Coupler wave / instabus UP 140

## Product and Applications Description

The Coupler wave / instabus UP 140 connects the GAMMA wave radio system to the GAMMA instabus. It is a special pushbutton wave available in the designs of the DELTA profil, DELTA style and DELTA i-system switch ranges.

The Coupler is plugged together with the corresponding switch range frame onto an instabus bus coupling unit UP 114 (must be separately ordered).

Transmission is bidirectional. Messages and commands which are received by radio are sent on the instabus and vice versa, i.e. received bus telegrams are forwarded by radio.

DELTA i-system	Coupler wave / <u>instabus</u>	UP 140	5WG3 140-2HB_1
DELTA profil	Coupler wave / <u>instabus</u>	UP 140	5WG3 140-2AB_1
DELTA style	Coupler wave / <u>instabus</u>	UP 140	5WG3 140-2GB_1

The pushbutton of the coupler enables optional operation by means of the instabus and radio.

In the middle of the pushbutton is an LED which is used to indicate telegram transmissions and the programming mode of the coupling unit.

The programming of the Coupler wave / instabus and the connection with other radio components takes place with the help of the ETS.

#### Note:

A bus coupling unit UP 114 Version 2.1 (21R1) or higher must be used for the Coupler wave / instabus UP 140.

## Application programs

### 25 CO Coupler wave / instabus 980B02

With the application program 25 CO Coupler wave / instabus 980B02, messages and commands received by radio are sent on the instabus and vice versa, i.e. received bus telegrams are forwarded by radio.

At present the following GAMMA wave devices can be connected to the instabus using the application program of the Coupler UP140:

- Pushbutton wave UP 210 with Switch insert sys
- Pushbutton wave UP 210 with Universal dimmer insert sys
- Pushbutton wave shutter UP 211 with Shutter control insert sys
- Transmitter battery wave UP 110
- Transmitter 230V wave UP 110
- Transmitter Actuator 230V wave UP 560
- Hand-held transmitter wave S 425
- Door/window contact wave AP 260
- Binary Input wave AP 261
- Smoke Detector module wave uni M 255
- Socket outlet switch wave/DECT S 563
- Socket outlet switch S 564

Functions of the local pushbutton of the Coupler UP 140 using the instabus and radio:

- 1 x changeover switching (Toggle On/Off) or
- 1 x dimming with changeover switching (On/Off) or
- 1 x shutter/blind movement with slat adjustment or
- 2 x scene save and retrieving

## Technical data

### Frequency band

- 868 MHz (transmission is not susceptible to interference; frequency band reserved for system and security applications)

### Range of radio control

- approx. 100 m (applies to free field applications)

### Power supply

- KNX/EIB-bus power supply: via the bus coupling unit UP 114
- KNX/EIB-bus current: max. 30 mA (triple standard bus load)

### Connections

- 10 pin bar (PEI) for connection to the bus coupling unit

### Control elements

- 1 pushbutton rocker, idle in middle position

### Indicator lamps

- 1 red LED in the middle of the pushbutton

### Mechanical data

- Housing: plastic
- Dimensions (L x W x D):
 

DELTA i-system	55x55x24mm (including spring)
DELTA profil	65x65x25mm (including spring)
DELTA style	68x68x27mm (including spring)
- Weight: approx. 35g
- Fire load: approx. 950kJ
- Mounting: placed on the bus coupling unit UP 114

### Electrical safety

- Pollution degree (acc. to IEC 60664-1): 2
- Protection (acc. to EN 60529): IP 20
- Overvoltage category (acc. to IEC 60664-1): III
- Device complies with EN 60669-2-1 and IEC 60664-1

### Environmental conditions

- Climatic conditions: EN 50090-2-2
- Ambient operating temperature: - 5 ... + 45°C
- Storage temperature: - 25 ... + 70°C
- Relative humidity (non-condensing): 5% to 93%

### EMC requirements

- complies with EN 60669-2-1, EN 301489, EN 300220

DELTA i-system	Coupler wave / <u>instabus</u>	UP 140	5WG3 140-2HB_1
DELTA profil	Coupler wave / <u>instabus</u>	UP 140	5WG3 140-2AB_1
DELTA style	Coupler wave / <u>instabus</u>	UP 140	5WG3 140-2GB_1

### Markings

- KNX / EIB



### CE norm

complies with the EMC regulations (residential buildings), low voltage regulations and R&TTE regulations

### Declaration of conformity

SIEMENS AG declares herewith that the coupler wave / instabus UP 140 comply with the basic requirements and other relevant regulations of Directive 1999/5/EG.

The CE declaration can be inspected at:

SIEMENS AG  
Siemensstraße 10  
93055 Regensburg

### Installation Instructions

#### Caution:

- The device may be used for interior installations and in dry rooms only.
- The installation of the device into metal walls has to be avoided since through this the range of radio control is reduced considerably.
- Occasionally the transmission range may be influenced by structural conditions (e.g. reinforced concrete) or electric / electronic sources of interference.
- A minimum distance of 0.5 m must be maintained between the transmitter and the relevant receivers.
- Though the radio transmission is carried out in the safe 868 MHz range, disruptions to the radio transmission cannot be excluded.
- The radio transmission is not suitable for security applications.



- The device must be mounted and commissioned by an authorized electrician.
- The device may not be inserted in the same box as 230 V devices.
- The device must not be opened.
- The device may be mounted to switch and socket combination box mounts if VDE-certified devices are used exclusively.

- For planning and construction of electric installations, the relevant guidelines, regulations and standards of the respective country are to be considered.

### Mounting

The Coupler wave / instabus UP 140 is plugged together with the corresponding frame onto the bus coupling unit UP 114. The electrical connection between the coupler and the bus coupling unit is thus established via the PEI.

#### Mounting the Coupler wave / instabus UP 140:

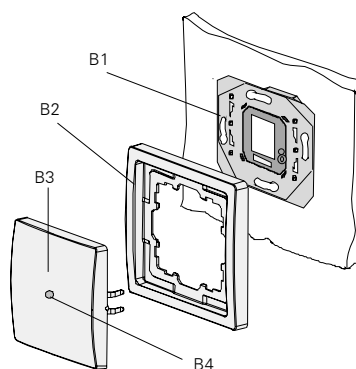

Diagram B

- B1 bus coupling unit UP 114
- B2 Frame
- B3 Coupler wave / instabus UP 140
- B4 LED

- 1) The bus coupling unit UP 114 is connected and mounted within the flush-type box (see mounting instructions for the bus coupling unit).
- 2) Plug the Coupler UP 140 together with the corresponding frame onto the bus coupling unit UP 114.

**Important:** Cut-out frames have to be used to integrate the coupler wave / instabus UP 140 into the DELTA profil range.

DELTA i-system	Coupler wave / <u>instabus</u>	UP 140	5WG3 140-2HB_1
DELTA profil	Coupler wave / <u>instabus</u>	UP 140	5WG3 140-2AB_1
DELTA style	Coupler wave / <u>instabus</u>	UP 140	5WG3 140-2GB_1

Disassembly:

Pull off the Coupler wave / instabus UP 140 together with the corresponding frame by hand (Diagram C).

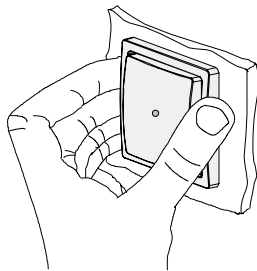
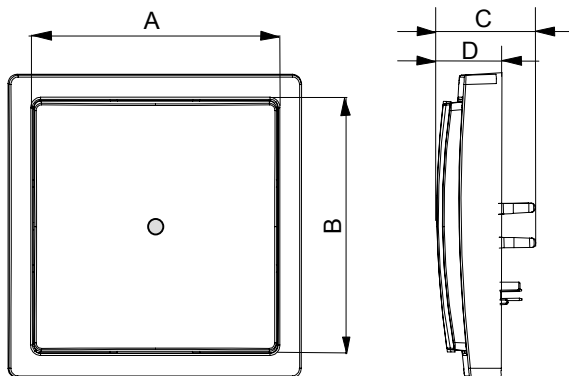

Diagram C

**Dimension drawing**

Dimensions in mm

	A	B	C	D
DELTA i-system	55	55	24	13
DELTA profil	65	65	25	14
DELTA style	68	68	27	16.5



**General Notes**

- The operating instructions must be handed over to the client.
- Any faulty device should be returned to the local Siemens office.
- If you have further questions concerning the product please contact our technical support:

☎ +49 (180) 5050-222  
 📞 +49 (180) 5050-223  
 🌐 [www.siemens.com/automation/support-request](http://www.siemens.com/automation/support-request)